



GLOBAL STEEL ENGINEERING LLC

The global design and engineering company

ABOUT US



GSE LLC

The team of professionals founded in 2011 focused on the full cycle of designing activities related to the construction and reconstruction of the industrial infrastructure objects of all levels of complexity

50+

highly qualified staff

OUR BENEFITS

- Result oriented
- High quality of deliverables
- Strict adherence to deadlines
- Use of modern software tools

OUR TEAM



Focus on the needs



Long-term solutions

**Search and offer of
the most optimal
solution**



OUR COMMITMENT TO CLIENTS



**High quality of the
project
implementation
according to the
latest international
industry standards**

**Continuous
improvement of the
provided services**



**The balance offer
that provides the
best mix of speed
and quality**

OUR CLIENTS



7

European countries



OUR WORK



11+

years of work

142+

projects

24+

happy clients

AREAS OF WORK

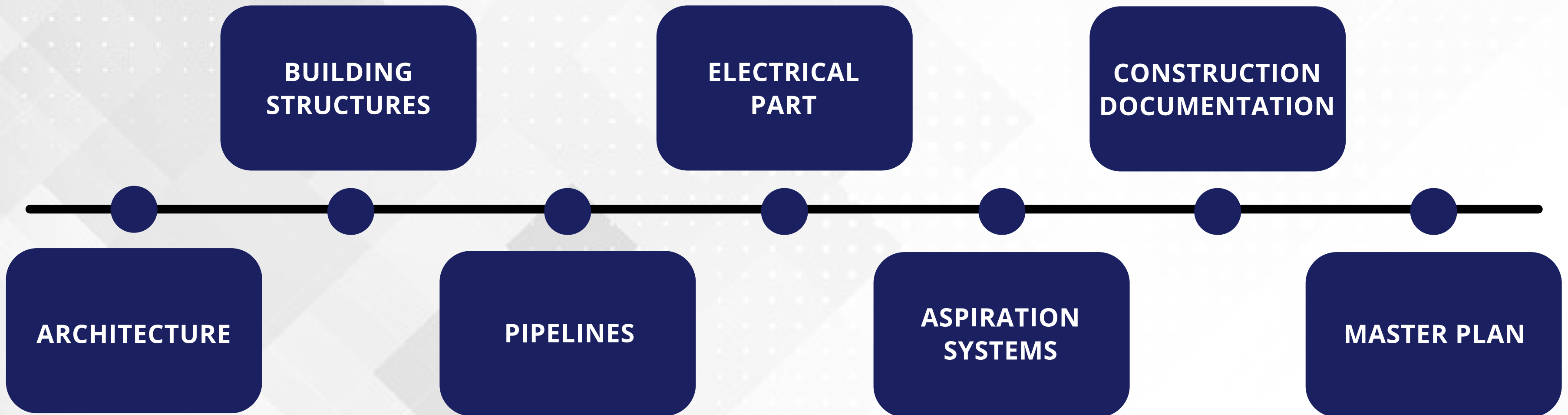

ARCHITECTURE

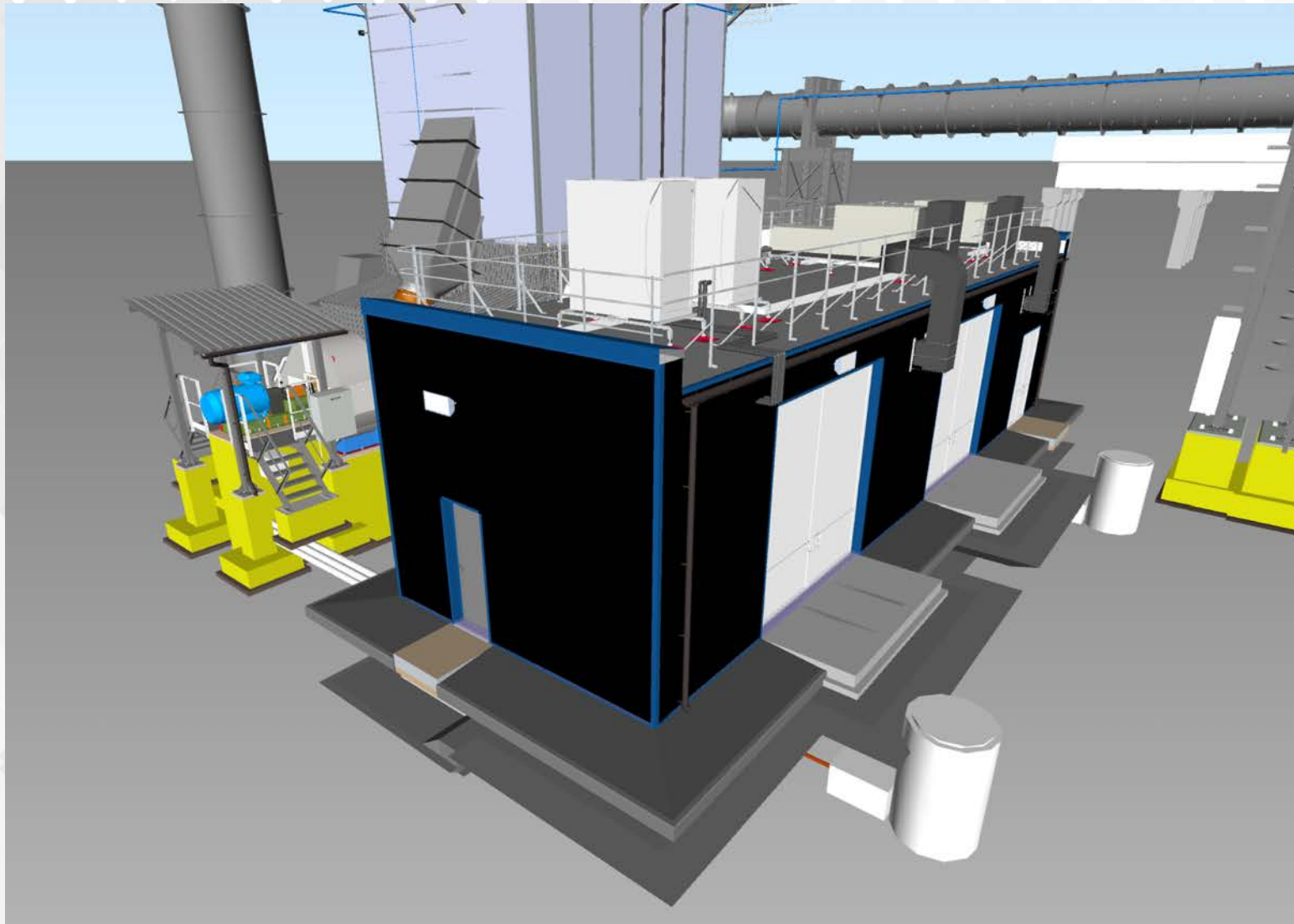

Architecture of buildings and structures

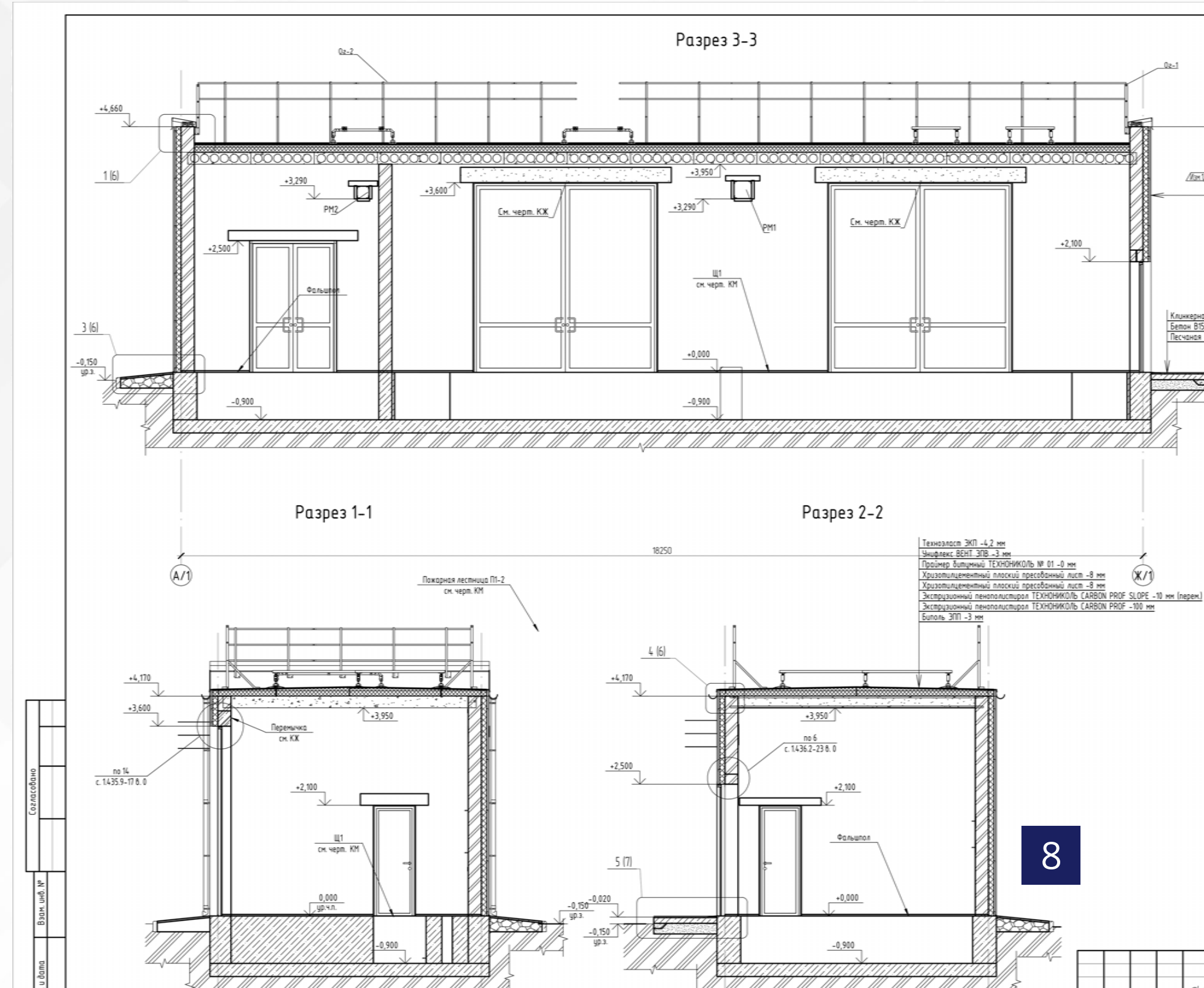

BUILDING STRUCTURES



Calculation and development of building structures (both from reinforced concrete and metal)

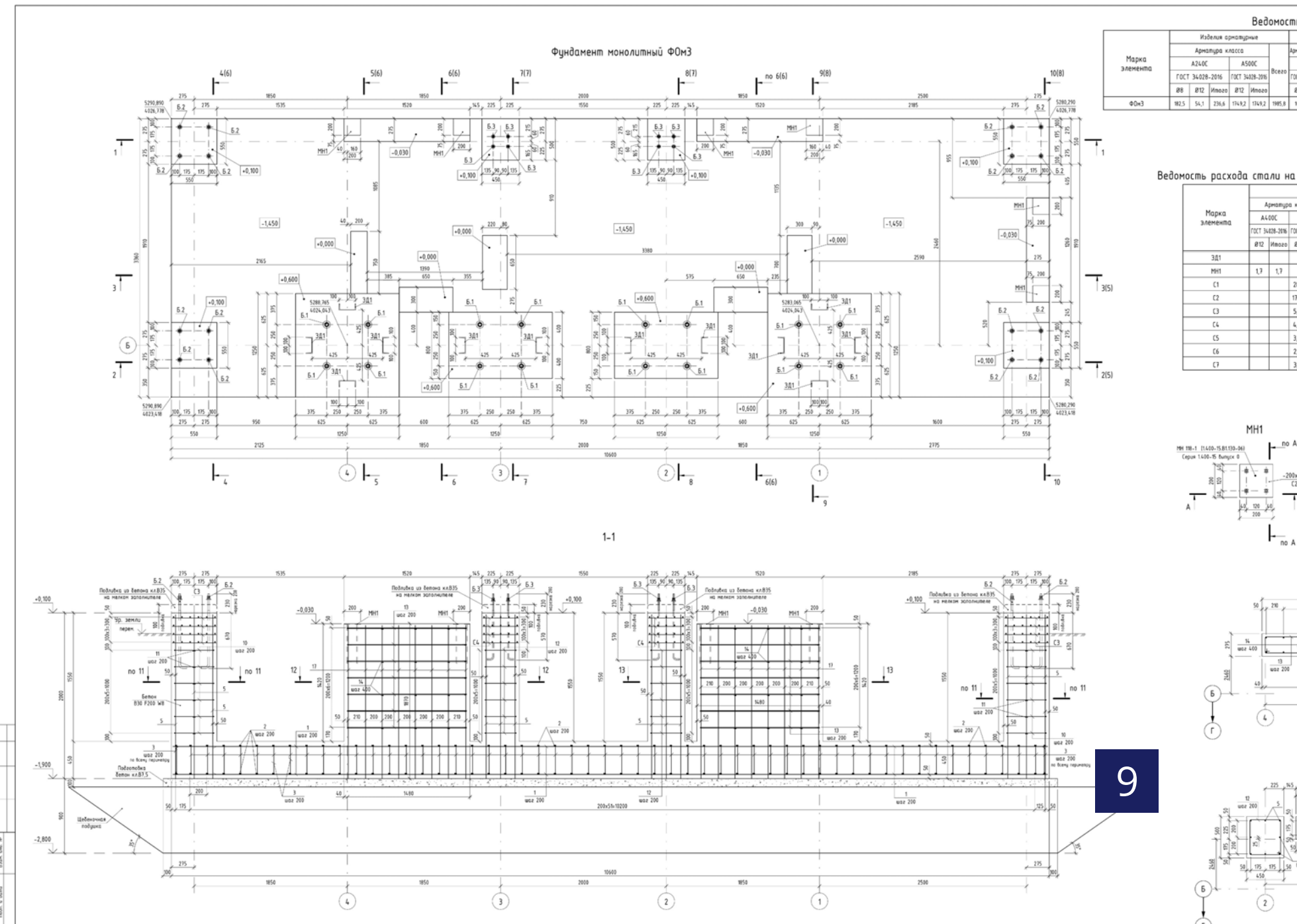
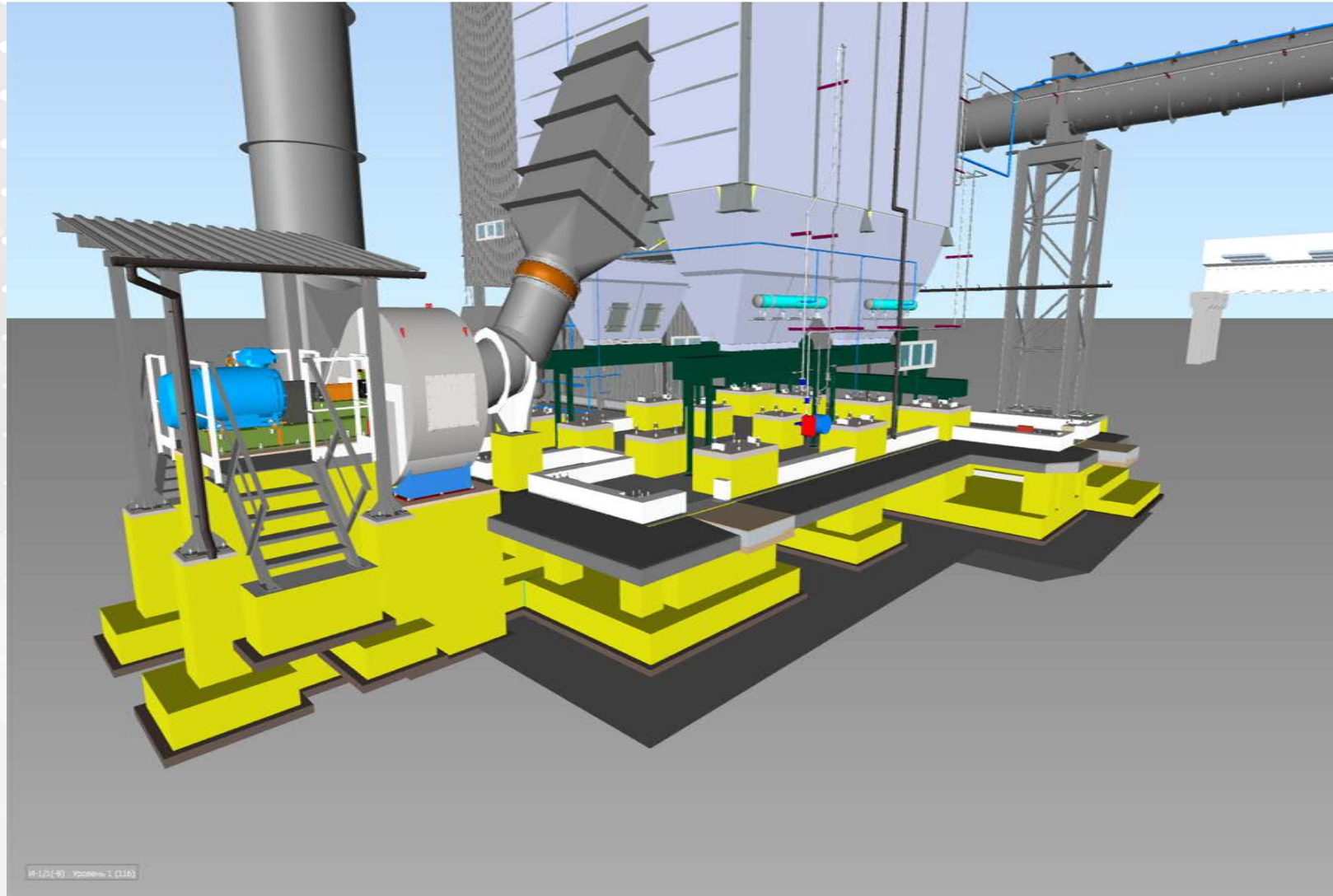

PIPELINES



Pipelines and PID schemes (energy environments: water supply, natural gas, compressed air, etc.)

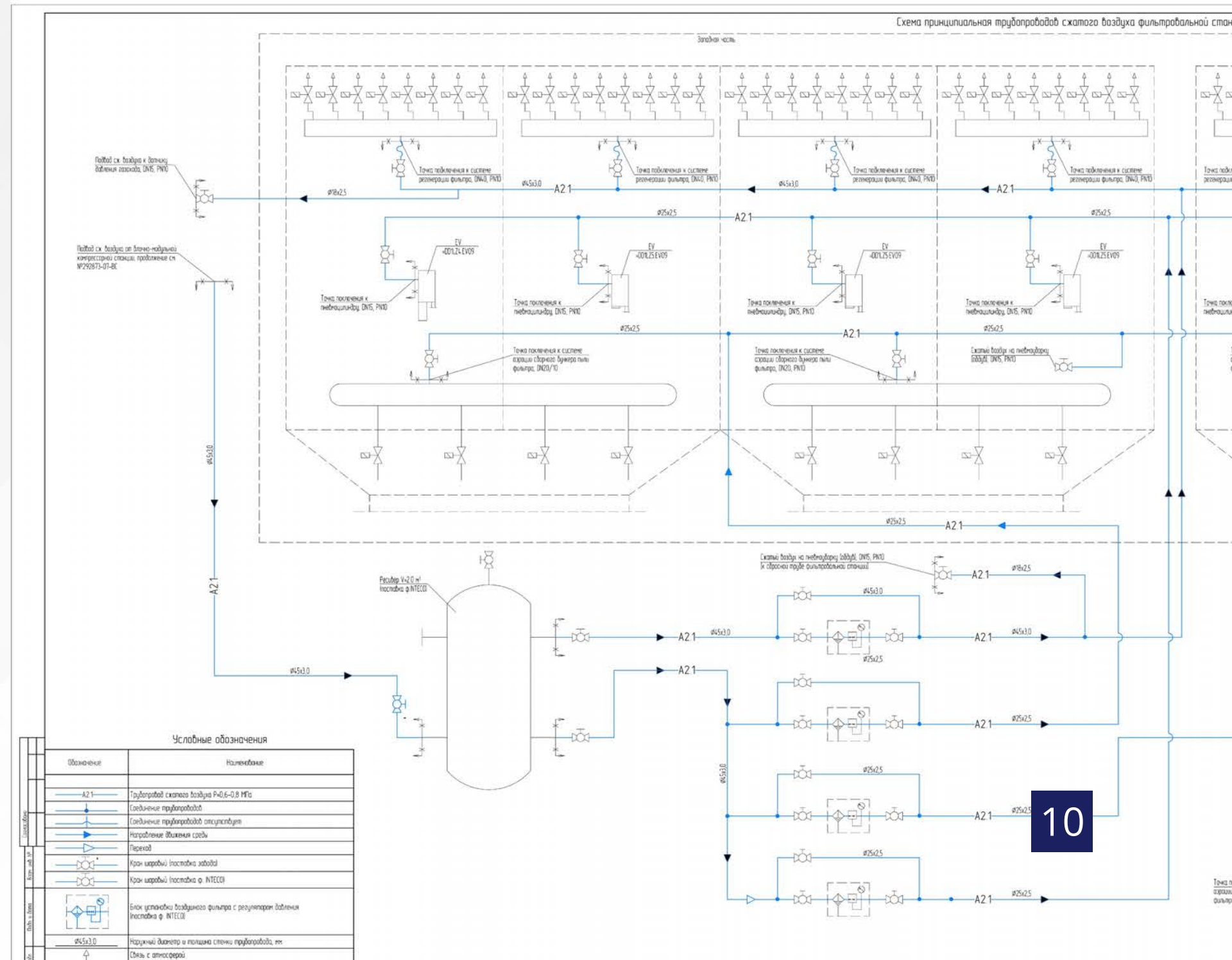
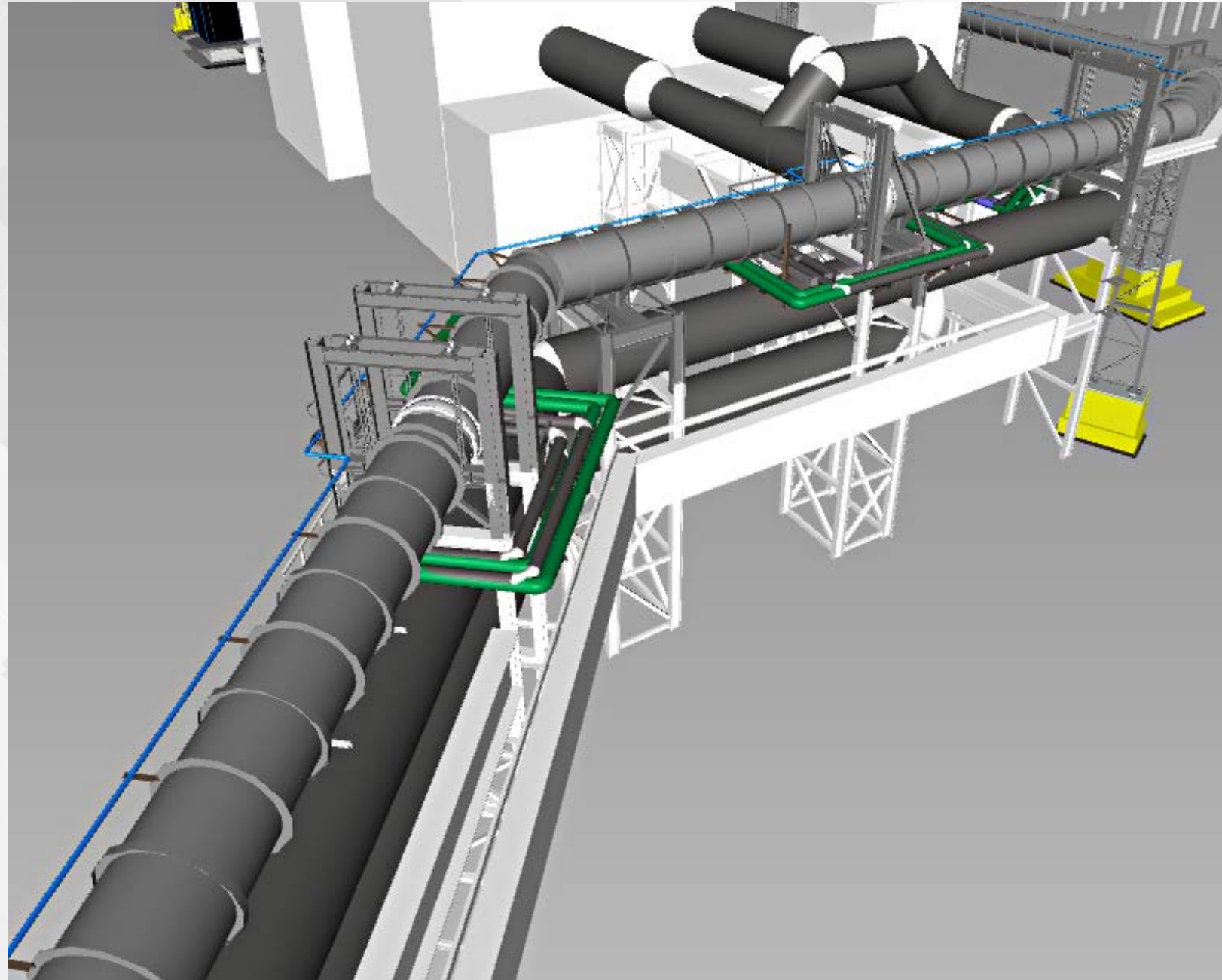

ELECTRICAL PART

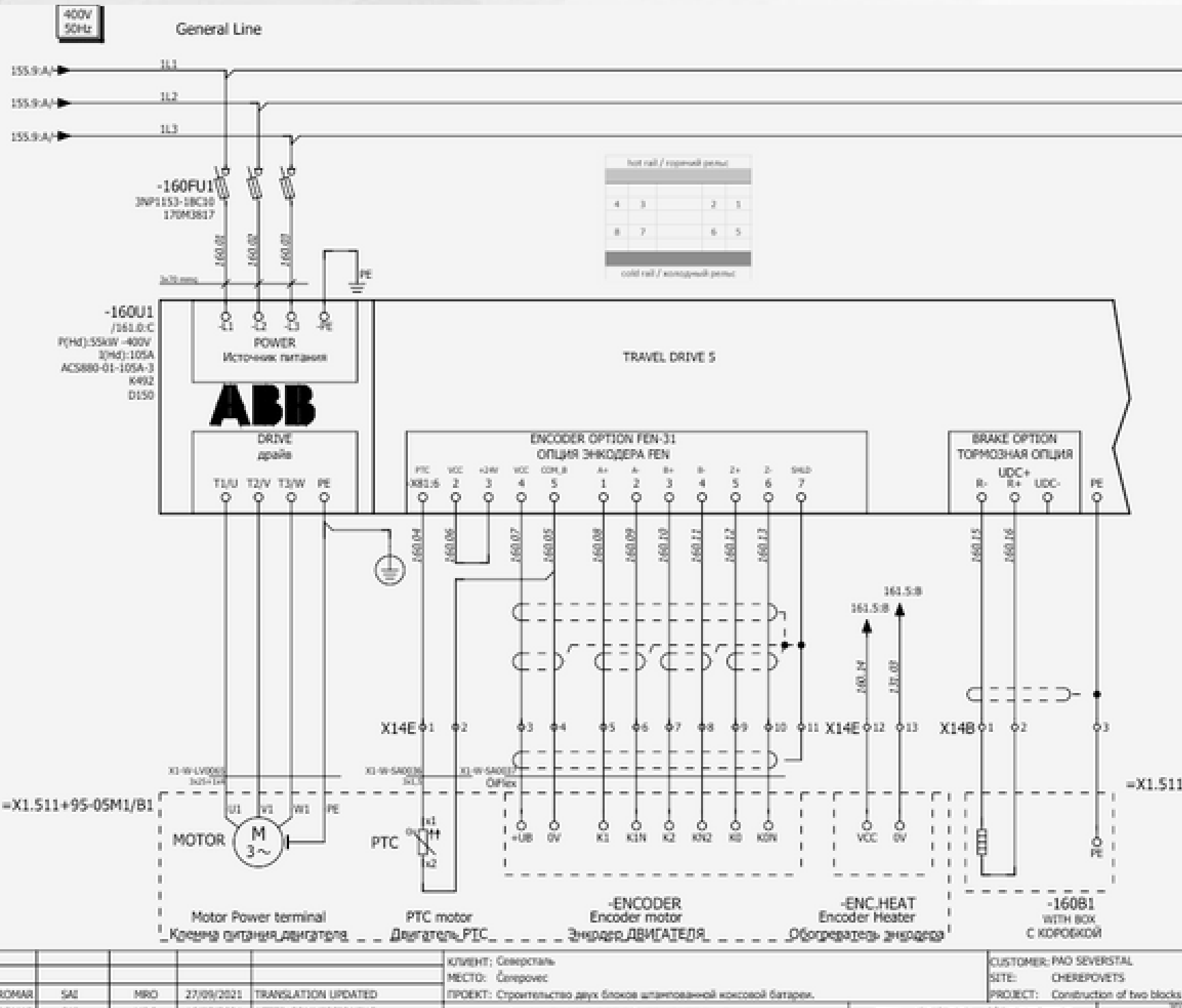

Design of cable structures and cable laying

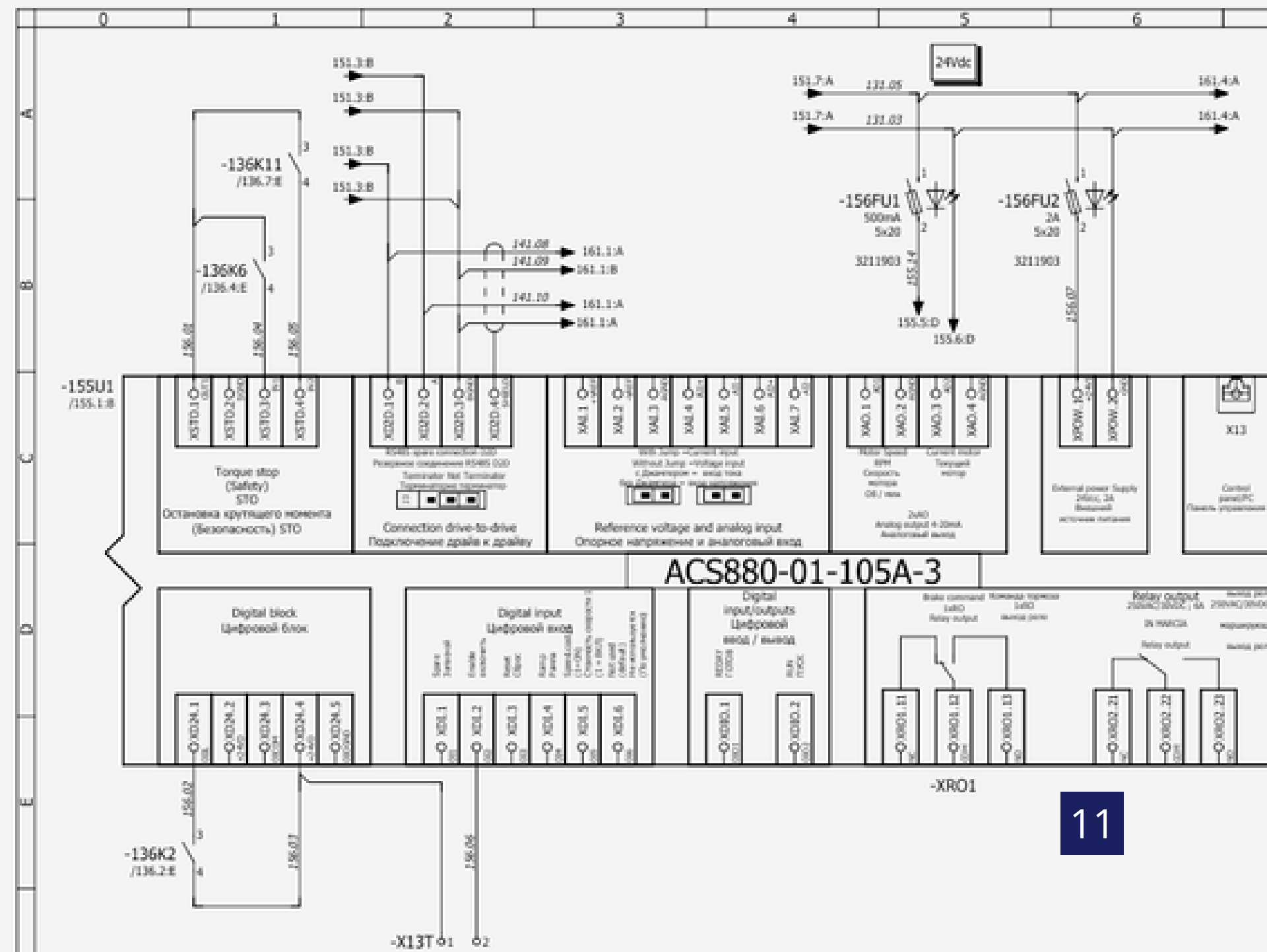

ASPIRATION SYSTEMS



Calculation and development of aspiration systems and process gas purification systems for sintering, steel making and blast furnaces)

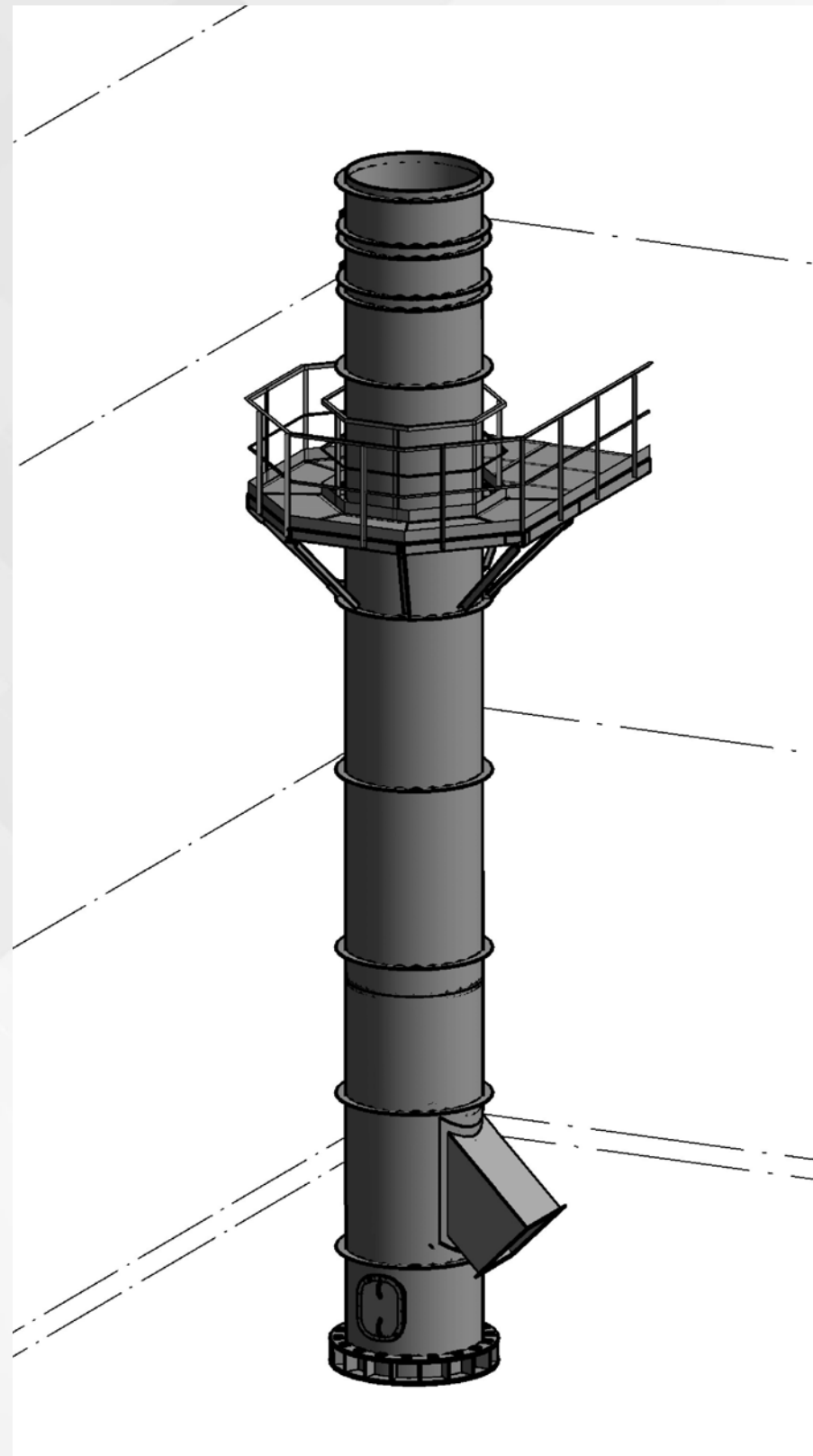

Изометрический вид

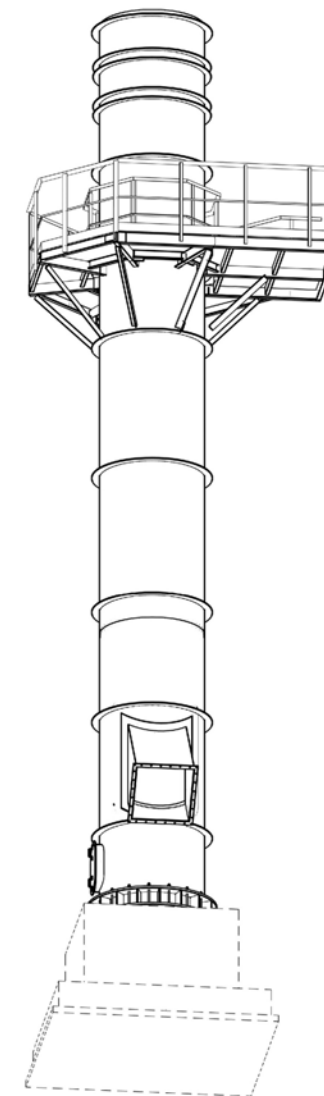

Разрез 1 - 1

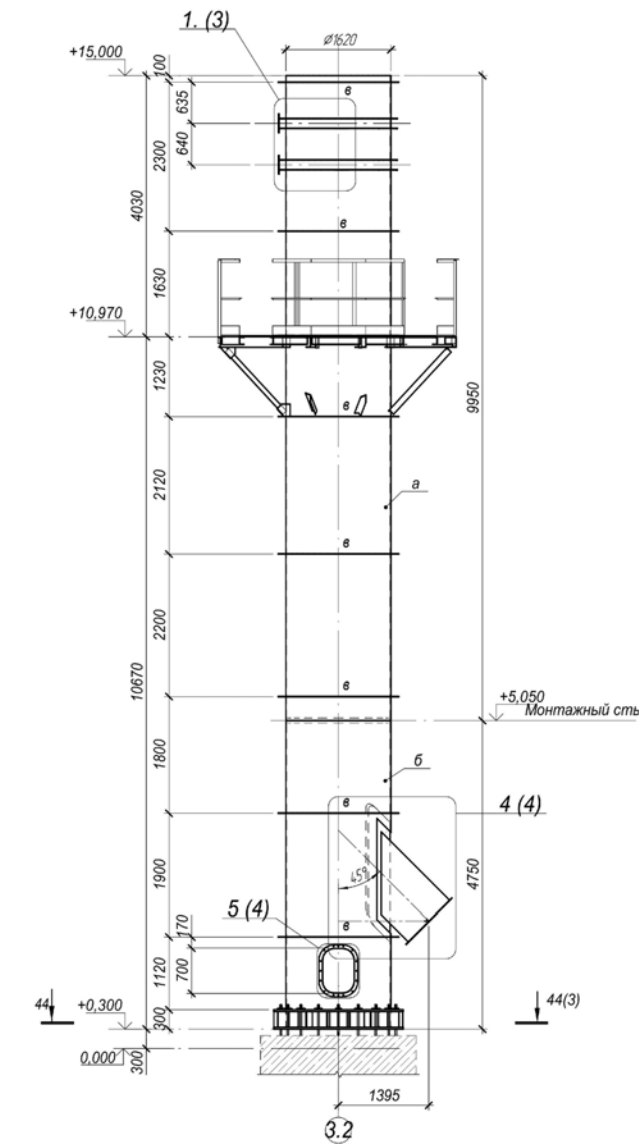

Разрез 2 - 2

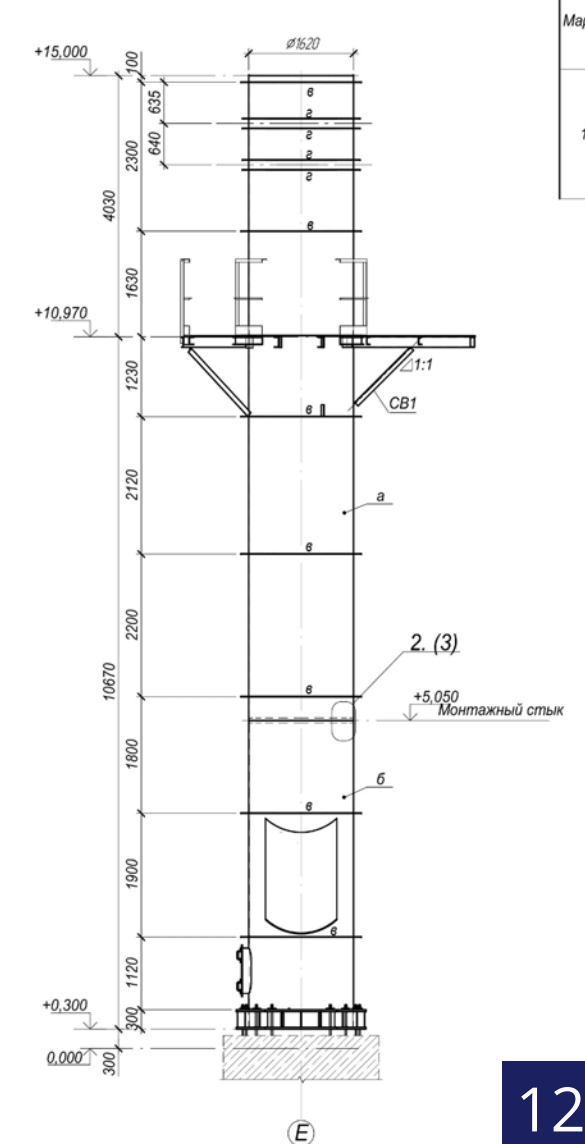

Расч

Марка	Привито знаков	у
1		

Марка элемента	
Б1	
Б2	
СВ1	
а	
б	
в	
г	
1.4	
1.3	Н1
	ОГП1
1.2	

Схема расположения элементов площадки на отм. +10.970



Схема расположения газотоводящего ствола на отм. +0.300

MASTER PLAN



Development of master plan with the layout of the complex facilities

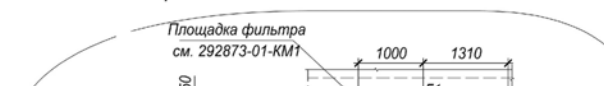
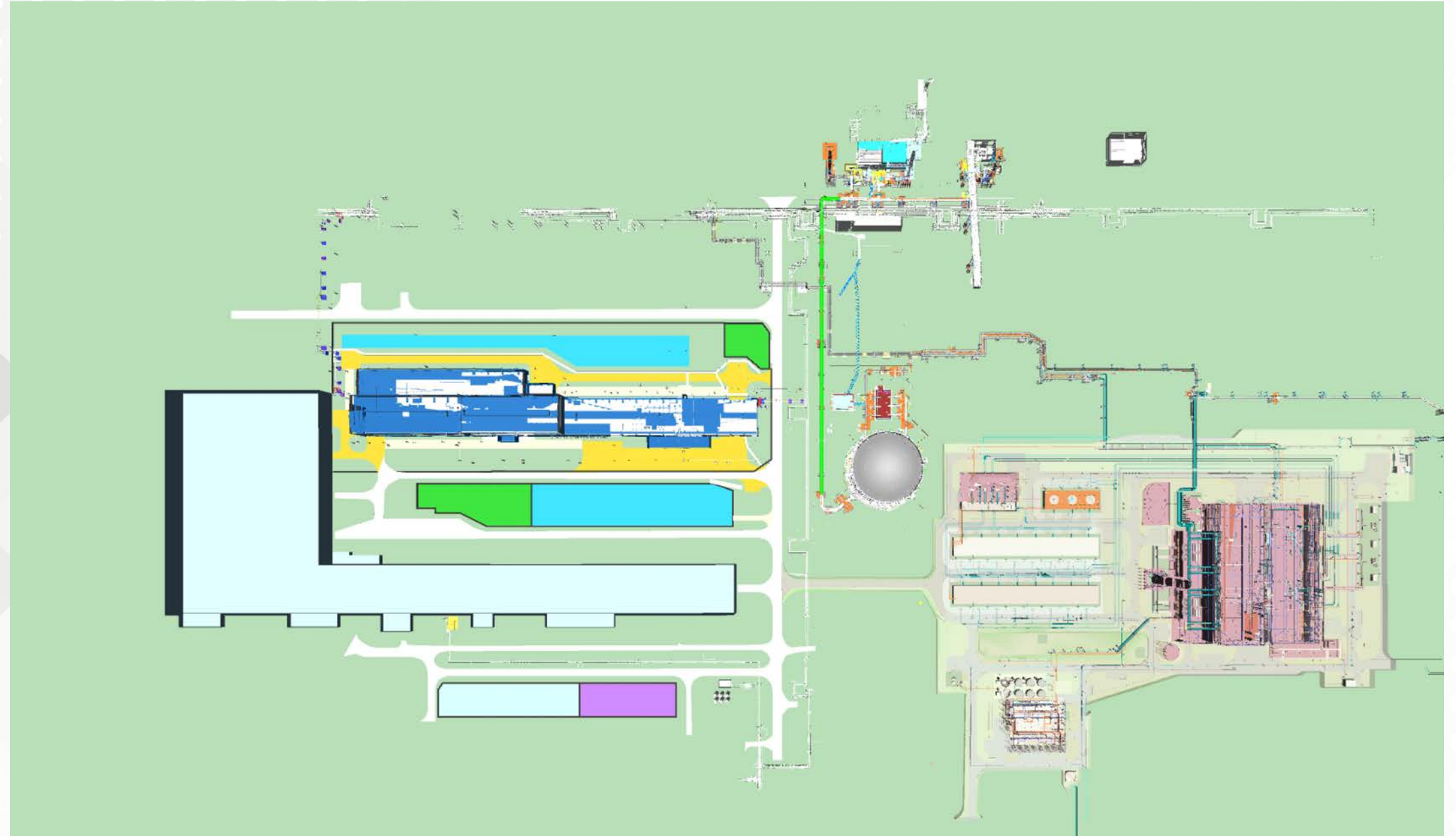
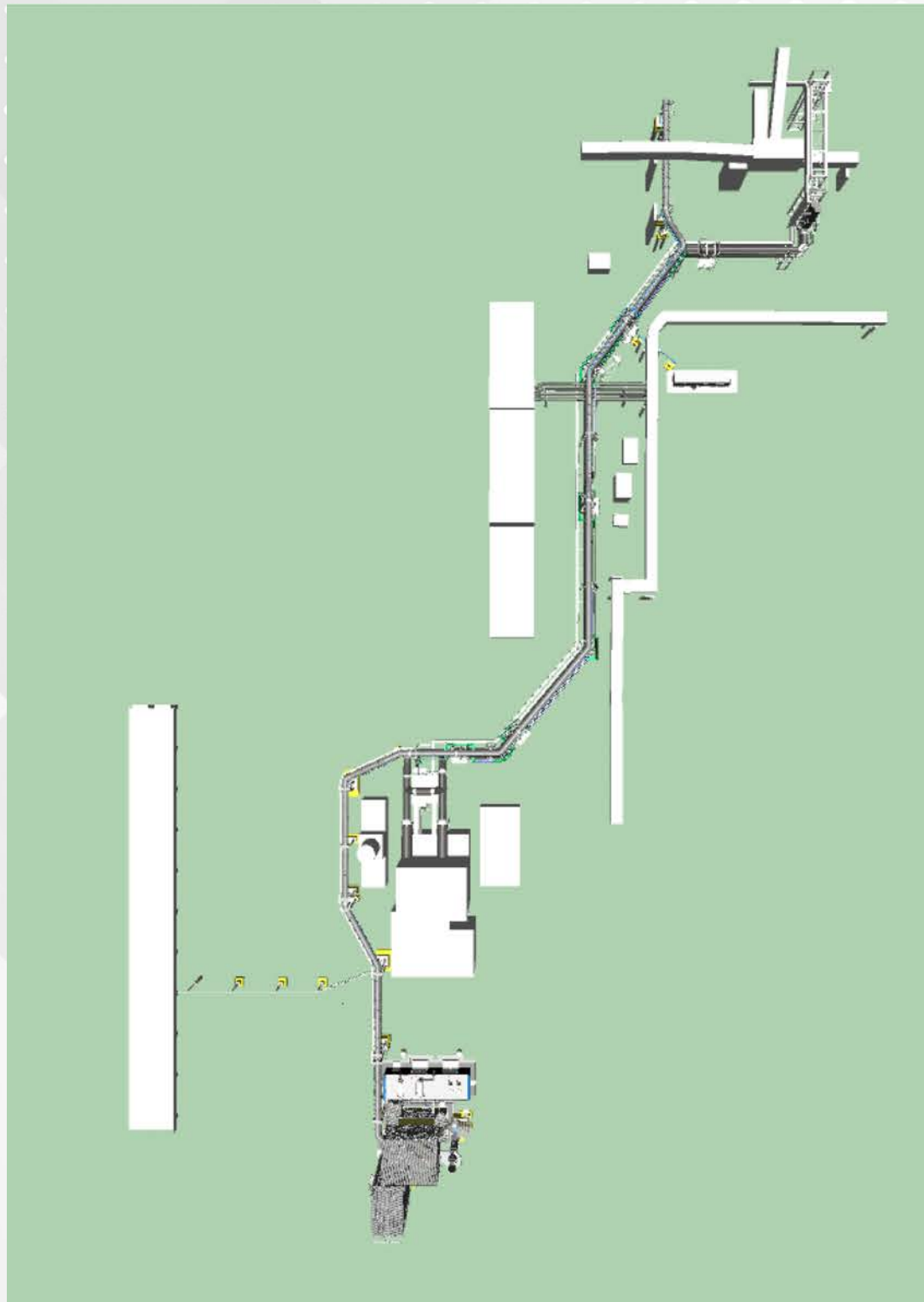

OUR PROJECTS

Gas cleaning installation for blast furnace 7

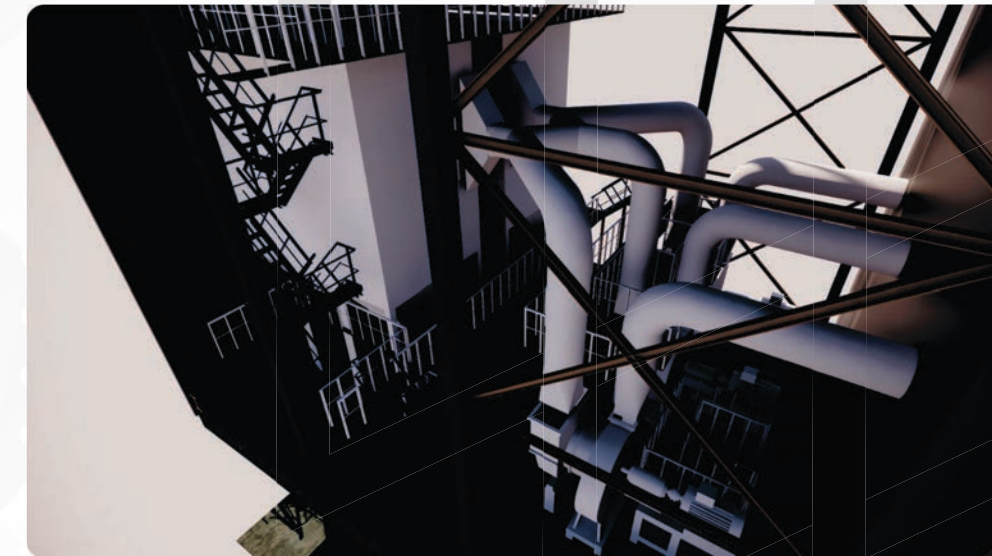

Gas cleaning installation of the converter

